

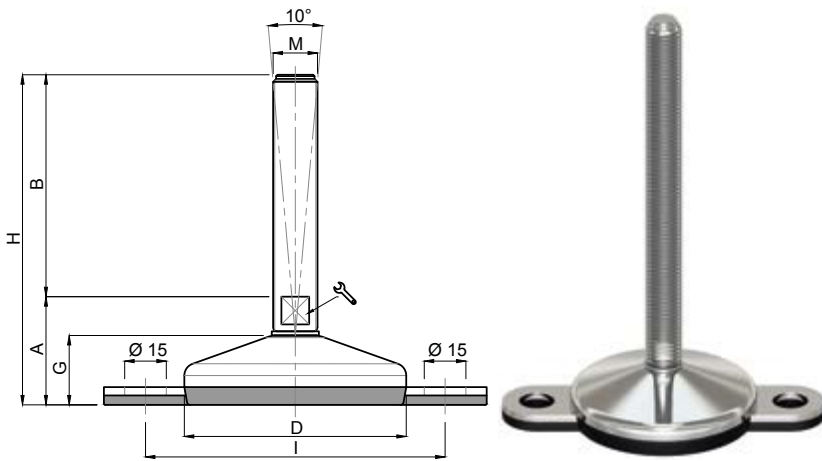

## Embases tôle inox

Ø 80

Embase inox  
Tige inox  
Pied articulé oscillant fixeable

CODE	DÉSIGNATION	DIMENSIONS								CHARGE MAXI
Standard		A	B	D		M	G	H	I	Newton
MA-25000/10/FF	M10x75	35	75	80	14	M10	25	110	108	10 000
MA-25002/10/FF	M10x100	35	100	80	14	M10	25	135	108	10 000
MA-25004/10/FF	M10x125	35	125	80	14	M10	25	160	108	10 000
MA-25000/12/FF	M12x75	35	75	80	14	M12	25	110	108	10 000
MA-25002/12/FF	M12x100	35	100	80	14	M12	25	135	108	10 000
MA-25004/12/FF	M12x125	35	125	80	14	M12	25	160	108	10 000
MA-25006/12/FF	M12x150	35	150	80	14	M12	25	185	108	10 000
MA-25000/FF	M14x75	35	75	80	14	M14	25	110	108	10 000
MA-25002/FF	M14x100	35	100	80	14	M14	25	135	108	10 000
MA-25004/FF	M14x125	35	125	80	14	M14	25	160	108	10 000
MA-25006/FF	M14x150	35	150	80	14	M14	25	185	108	10 000
MA-25008/FF	M14x175	38	175	80	14	M14	25	210	108	10 000
MA-25020/FF	M16x75	38	75	80	13	M16	25	113	108	10 000
MA-25022/FF	M16x100	38	100	80	13	M16	25	138	108	10 000
MA-25024/FF	M16x125	38	125	80	13	M16	25	163	108	10 000
MA-25026/FF	M16x150	38	150	80	13	M16	25	188	108	10 000
MA-25028/FF	M16x175	38	175	80	13	M16	25	213	108	10 000
MA-25030/FF	M16x200	38	200	80	13	M16	25	238	108	10 000
MA-25040/FF	M20x75	38	75	80	17	M20	25	113	108	10 000
MA-25042/FF	M20x100	38	100	80	17	M20	25	138	108	10 000
MA-25044/FF	M20x125	38	125	80	17	M20	25	163	108	10 000
MA-25046/FF	M20x150	38	150	80	17	M20	25	188	108	10 000
MA-25048/FF	M20x175	38	175	80	17	M20	25	213	108	10 000
MA-25050/FF	M20x200	38	200	80	17	M20	25	238	108	10 000
MA-25052/FF	M20x225	38	225	80	17	M20	25	263	108	10 000
MA-25054/FF	M20x250	38	250	80	17	M20	25	288	108	10 000
MA-25070/FF	M24x75	40	75	80	20	M24	25	115	108	10 000
MA-25072/FF	M24x100	40	100	80	20	M24	25	140	108	10 000
MA-25074/FF	M24x125	40	125	80	20	M24	25	165	108	10 000
MA-25076/FF*	M24x150	40	150	80	20	M24	25	190	108	10 000
MA-25078/FF	M24x175	40	175	80	20	M24	25	215	108	10 000
MA-25080/FF*	M24x200	40	200	80	20	M24	25	240	108	10 000
MA-25082/FF	M24x225	40	225	80	20	M24	25	265	108	10 000

\* Référence disponible au pas fin (code + P2)

matière

Embase en inox AISI 304 (316 sur demande).  
Tige en inox AISI 304 (316 sur demande) livrée sans écrou.  
Semelle en caoutchouc NBR vulcanisé dureté 80° shore.

note

Facilité de fixation due au grand entraxe tige-oreille. Excellent rapport performance/coût.  
Réalisation de dimensions et finitions spéciales de tiges filetées dès 200 pièces.  
Semelle extrêmement résistante aux ripages ou déplacements de machines.